

**basic**<sup>®</sup>  
COATINGS



***Sand Dragon***<sup>™</sup>

20", 28" ORBITAL SANDING MACHINES



## Operator and Parts Manual

400 Van Camp Road • Bowling Green, Ohio 43402 • Customer Service: 800-441-1934  
Fax: 800-942-2007 • Technical Service: 877-856-5954 • [www.basicoatings.com](http://www.basicoatings.com)



## SPECIFICATIONS

Length - 20 in. or 28 in.

Width - 20 in.

Height - 48 in.

Weight - 165 Lbs., 215 Lbs., or 288 Lbs.

Speed - 3400 RPM

Pad Size - 20" x 14" or 20" x 28"

Drive motor - 1.5 HP, 120v, 12A, 60 Hz

Cord - 14-3 ST, 50 ft. or 12-3 ST, 75 ft.

## SAFETY

**READ AND UNDERSTAND THE MANUAL  
BEFORE OPERATING THIS MACHINE.**

Do not operate in explosive areas or use near flammable liquids or gases or dust.

Attach only to properly grounded outlet.

Do not expose to rain, store indoors.

Do not operate the machine with a damaged cord or plug.

Do not block or disconnect the safety lever.

Do not leave the machine plugged in while unattended.

Unplug the machine before servicing.

Do not put fingers under the pad or pad holder.

Unplug the machine before installing or removing the pad.

Never inhale dust created by the use of this machine.

Do not use machine if it has been sprayed with water or left out in the rain.

## OPERATING INSTRUCTIONS

Check machine for damage to cord or plug. Use suitable pads or brushes. Always use a 1" red pad between the gripper face and abrasive pad.

### OPERATING ENVIRONMENT:

The Sand Dragon™ is intended to be used to remove floor finish by dry abrasion. The machine is also intended for dry screening of wood floors. Do not use the machine with wet stripping chemicals.

### TO INSTALL OR CHANGE THE PAD:

1. Unplug the machine.
2. Tip the machine back on the wheels.
3. Install brush or pad driver.
4. Center the pad on the pad driver.

### TO OPERATE THE MACHINE:

1. Plug into a grounded outlet.
2. The machine can be operated with the handle in an upright position or lowered position, whichever is most comfortable for the operator.
3. Handle does not need to be locked during use, some operators prefer to use the machine with the handle position unlocked and floating.
4. Press the safety lever and squeeze the trigger to start the machine.
5. Store the machine with the red carrier pad installed on the machine.
6. Use only new or clean pads and reverse them as needed.

## ROUTINE MAINTENANCE

To maintain appearance, wipe the machine with a damp cloth or clean with forced air after every use.

**Warning** – Unplug the machine before servicing

**Prior to use:** Check the power cord. Never operate the equipment if the power cord is frayed, cut, or ground is missing. Check the vacuum hose and connections if equipped with this option. Check grip face and pad driver, inspect for wear or debris.

**After use:** Clean pad and base plate assembly, replace pad as needed. Inspect grip face for wear. Remove debris from between grip face and base plate.

**Weekly:** Check grip face for wear. Use a vacuum cleaner to clean away debris from around the motor assembly, weights, and base plate.

**Scheduled Service:** Replace all rubber isolators every 250 hours of use. Order kit EP50252 for 20" machine or EP50253 for 28" machine. Replace main bearing assembly every 500 hours of use. Order kit EP50255 for 20" machine or EP50256 for 28" machine.

# 20" AND 28" ORBITAL WIRING DIAGRAM

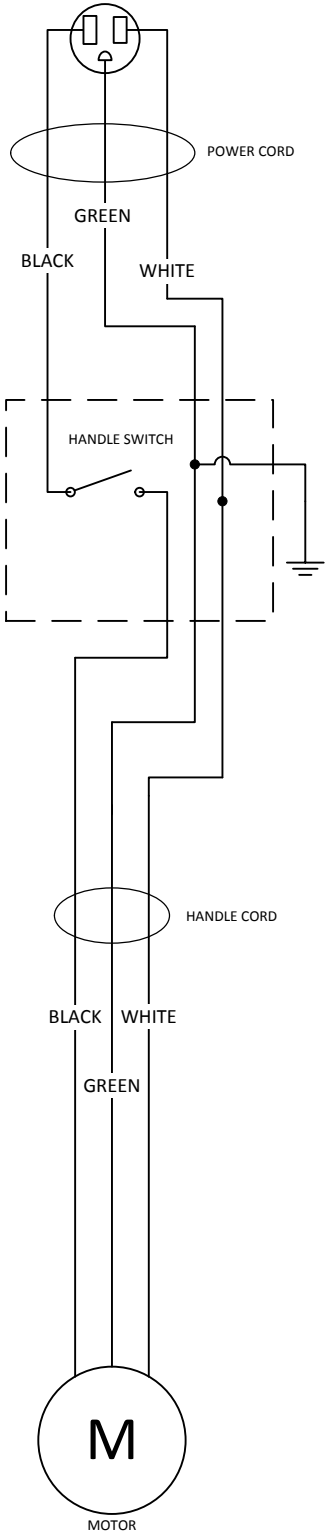

# 20" ORBITAL EXPLODED VIEW

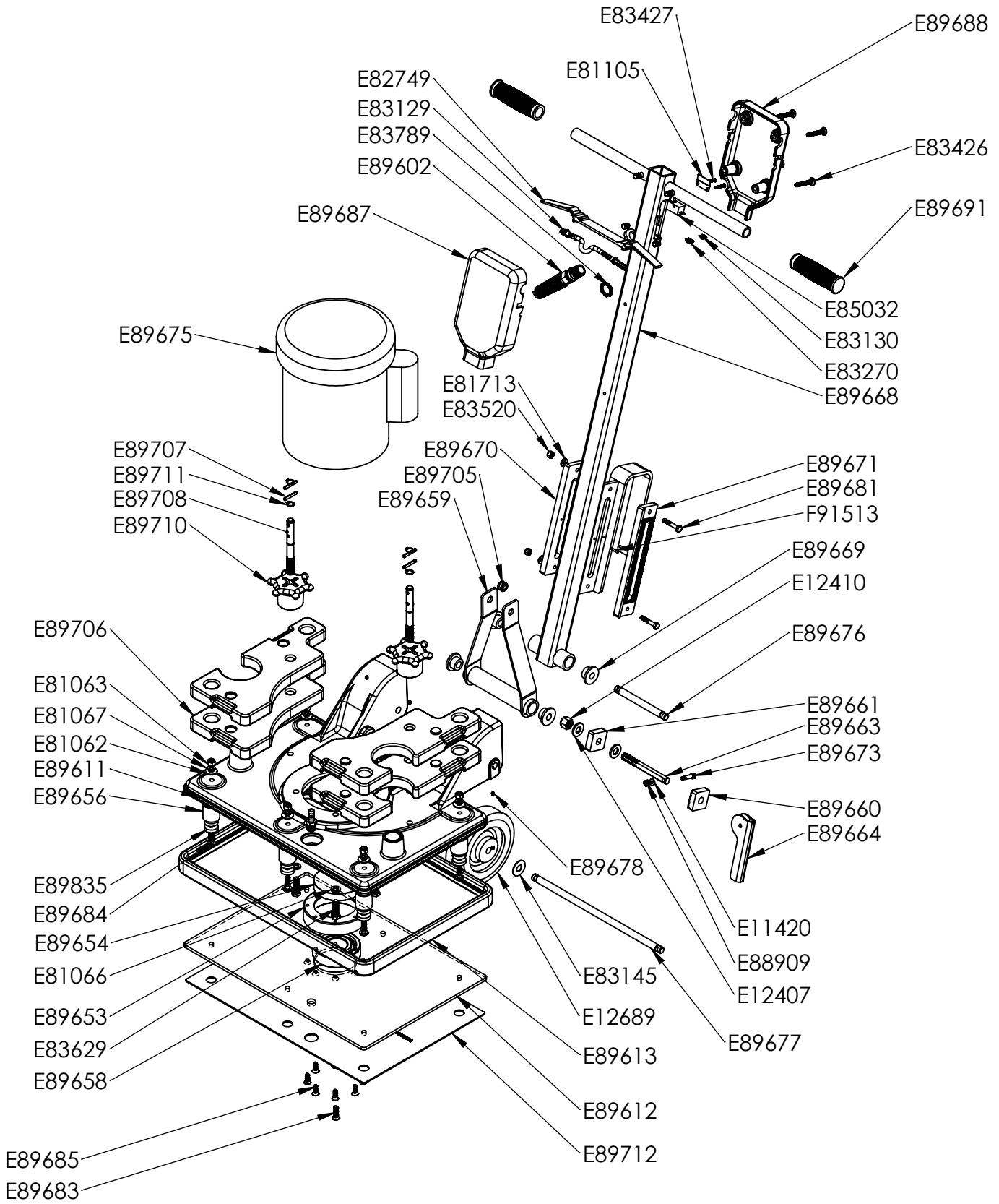

# 20" ORBITAL MACHINE PARTS LISTING

Item #	Part #	Description	Qty.
1	E10080	Fitting, .375 NPSM TO .375 Hose Barb	1
2	E11420	Flat Washer #10 Zinc	1
3	E12407	Washer, 1/2" SAE, Zinc	2
4	E12410	Nut, 1/2"-13, Nylon Lock, Grade 5, Zinc	1
5	E12689	Wheel 6 In. Dia.	2
6	E81062	Flat Washer 5/16 USS, Zinc	6
7	E81063	Nyloc Hex Nut 5/16-18 Zinc	6
8	E81066	Split Lock washer .375 Zinc	4
9	E81067	Lock Washer 5/16 Zinc	6
10	E81105	Plate, Switch	1
11	E81713	Flat Washer 0.250 Zinc	2
12	E82749	Handle Trigger Switchbox	1
13	E83129	Safety Lock	1
14	E83130	Spring, Extension	1
15	E83145	Nylon Washer 1/2 ID x 1.25 OD	4
16	E83270	Spring Clip	1
17	E83426	Truss Head Screw, 1/4-20 x 1.750 Lg Zinc	4
18	E83427	Screw 6-32 x 1.00 Lg	2
19	E83520	Nyloc Hex Nut 1/4-20 Zinc	2
20	E83629	Hex Head Bolt 3/8-16 x 1-1/4 Lg	4
21	E83789	Strain Relief Nut, Metal	1
22	E85032	Switch, 25 AMP, 1/5 HP, 125 VAC	1
23	E88909	Nut, Nylon Lock#10-24, Zinc	1
24	E89602	Cord Grip	1
25	E89611	Cast 13-19 Motor Mount Plate	1
26	E89612	13-20 Pad Driver Backing Plate	1
27	E89613	20 Bumper	1
28	E89653	Bearing Retainer	1
29	E89654	Eccentric	1
30	E89656	Dampener	1
31	E89658	Bearing, 6308 2RS/C3	1

Item #	Part #	Description	Qty.
32	E89659	Handle Support Weldment	1
33	E89660	Cam Lock Foot	1
34	E89661	Cam Lock Slider Foot	1
35	E89663	Cam Lock Tension Bolt	1
36	E89664	Cam Lock Handle	1
37	E89668	Handle Weldment	1
38	E89669	Step Bushing	4
39	E89670	Cam Lock Slide Bar	1
40	E89671	Cam Lock Bar	1
41	E89673	Screw SH Shoulder 0.25 Dia. X 0.75 Lg SS	1
42	E89675	Imperial Motor	1
43	E89676	Handle Axle	1
44	E89677	Handle Support Axle	1
45	E89678	Set Screw, Socket 10-24 X 0.19 SS	10
46	E89681	Hex Bolt 1/4-20 X1.5 Lg. Zinc	2
47	E89684	SCREW, PAN HD PHIL .03125-18 X 1.0 LG SS	6
48	E89685	SCREW, FLAT HD PHIL .25-20 X .75 LG SS	8
49	E89687	HANDLE SWITCH BOX FRONT	1
50	E89688	HANDLE SWITCH BOX REAR	1
51	E89691	Hand Grip	2
52	E89705	Gromment	1
53	E89706	20 Inch Weight	4
54	E89708	Center Bolt	2
55	E89709	Dowel Pin-Weight Holder	4
56	E89710	Knob	2
57	E89711	Retaining Ring 0.50 In Dia. Shaft	4
58	E89712	Flex Loc Pad	1
59	E89835	Washer, Nylon 0.34 I.D. x 1.26 O.D. x 0.25 Thk	12
60	F91513	Spring Pin	2
61	Label	Label	1

# 28" ORBITAL EXPLODED VIEW

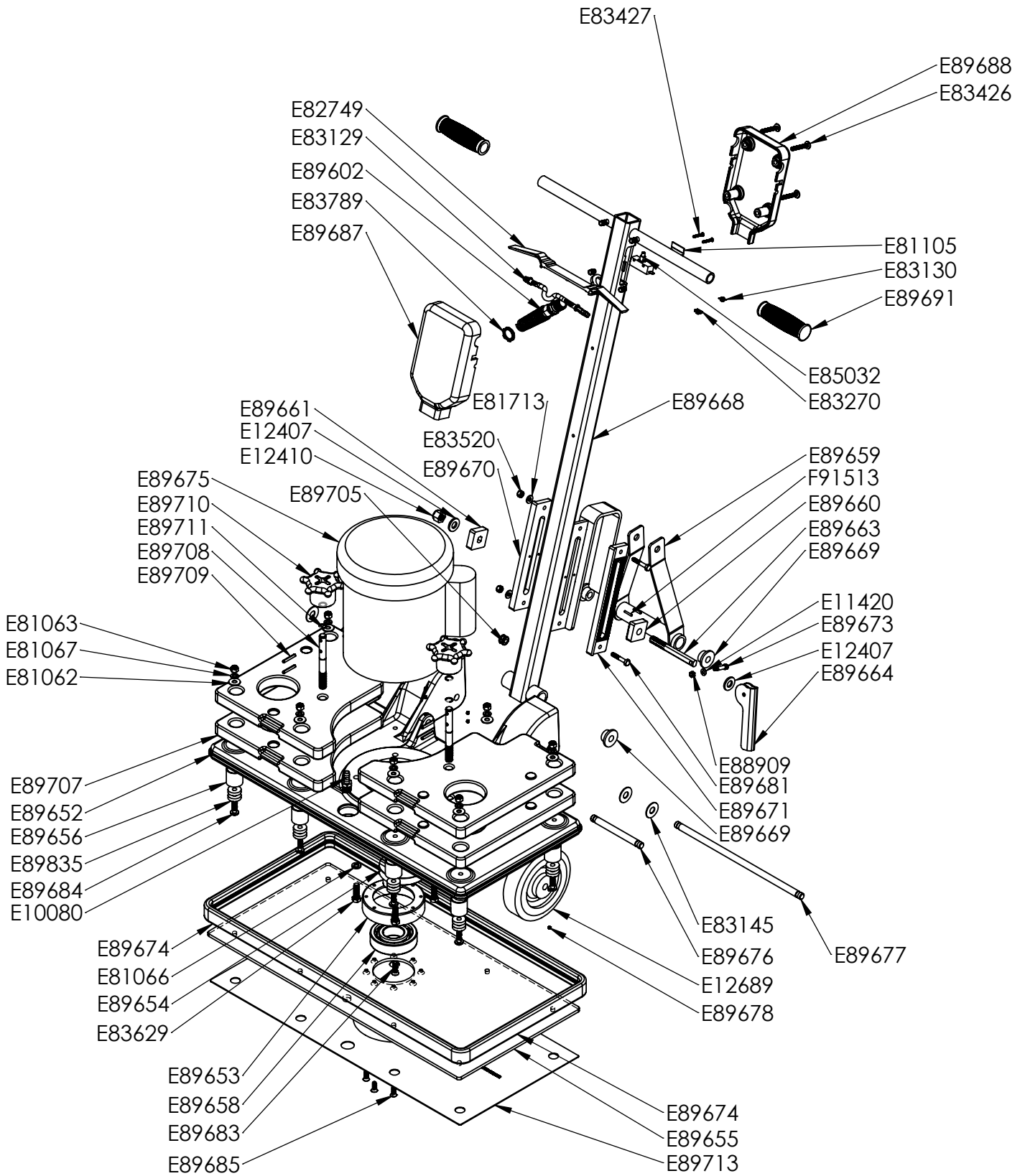

## 28" ORBITAL MACHINE PARTS LISTING

Item #	Part #	Description	Qty.
1	E10080	Fitting, .375 NPSM TO .375 Hose Barb	1
2	E11420	Flat Washer #10 Zinc	1
3	E12407	Washer, 1/2" SAE, Zinc	2
4	E12410	Nut, 1/2"-13, Nylon Lock, Grade 5, Zinc	1
5	E12689	Wheel 6 In. Dia.	2
6	E81062	Flat Washer 5/16 USS, Zinc	8
7	E81063	Nyloc Hex Nut 5/16-18 Zinc	8
8	E81066	Split Lock washer .375 Zinc	4
9	E81067	Lock Washer 5/16 Zinc	8
10	E81105	Plate, Switch	1
11	E81713	Flat Washer 0.250 Zinc	2
12	E82749	Handle Trigger Switchbox	1
13	E83129	Safety Lock	1
14	E83130	Spring, Extension	1
15	E83145	Nylon Washer 1/2 ID x 1.25 OD	4
16	E83270	Spring Clip	1
17	E83426	Truss Head Screw, 1/4-20 x 1.750 Lg Zinc	4
18	E83427	Screw 6-32 x 1.00 Lg	2
19	E83520	Nyloc Hex Nut 1/4-20 Zinc	2
20	E83629	Hex Head Bolt 3/8-16 x 1-1/4 Lg	4
21	E83789	Strain Relief Nut, Metal	1
22	E85032	Switch, 25 AMP, 1/5 HP, 125 VAC	1
23	E88909	Nut, Nylon Lock#10-24, Zinc	1
24	E89602	Cord Grip	1
25	E89652	Cast Motor Mount Plate	1
26	E89653	Bearing Retainer	1
27	E89654	Eccentric	1
28	E89655	Pad Driver Backing Plate	1
29	E89656	Dampener	1
30	E89658	Bearing NTN 6008LU	1
31	E89659	Handle Support Weldment	1

Item #	Part #	Description	Qty.
32	E89660	Cam Lock Foot	1
33	E89661	Cam Lock Slider Foot	1
34	E89663	Cam Lock Tension Bolt	1
35	E89664	Cam Lock Handle	1
36	E89668	Handle Weldment	1
37	E89669	Step Bushing	4
38	E89670	Cam Lock Slide Bar	1
39	E89671	Cam Lock Bar	1
40	E89673	Screw SH Shoulder 0.25 Dia. X 0.75 Lg SS	1
41	E89674	28 Bumper	1
42	E89675	Imperial Motor	1
43	E89676	Handle Axle	1
44	E89677	Handle Support Axle	1
45	E89678	Set Screw, Socket 10-24 X 0.19 SS	10
46	E89681	Hex Bolt 1/4-20 X1.5 Lg. Zinc	2
47	E89684	SCREW, PAN HD PHIL .03125-18 X 1.0 LG SS	8
48	E89685	SCREW, FLAT HD PHIL .25-20 X .75 LG SS	8
49	E89687	HANDLE SWITCH BOX FRONT	1
50	E89688	HANDLE SWITCH BOX REAR	1
51	E89691	Hand Grip	2
52	E89705	Gromment	1
53	E89707	28 Inch Weight	4
54	E89708	Center Bolt	2
55	E89709	Dowel Pin-Weight Holder	4
56	E89710	Knob	2
57	E89711	Retaining Ring 0.50 In Dia. Shaft	4
58	E89713	Flex Loc Pad	1
59	E89835	Washer, Nylon 0.34 I.D. x 1.26 O.D. x 0.25 Thk	16
60	F91513	Spring Pin	2
61	Label	Label	1

# PAD DRIVER REPLACEMENT BEARING KIT

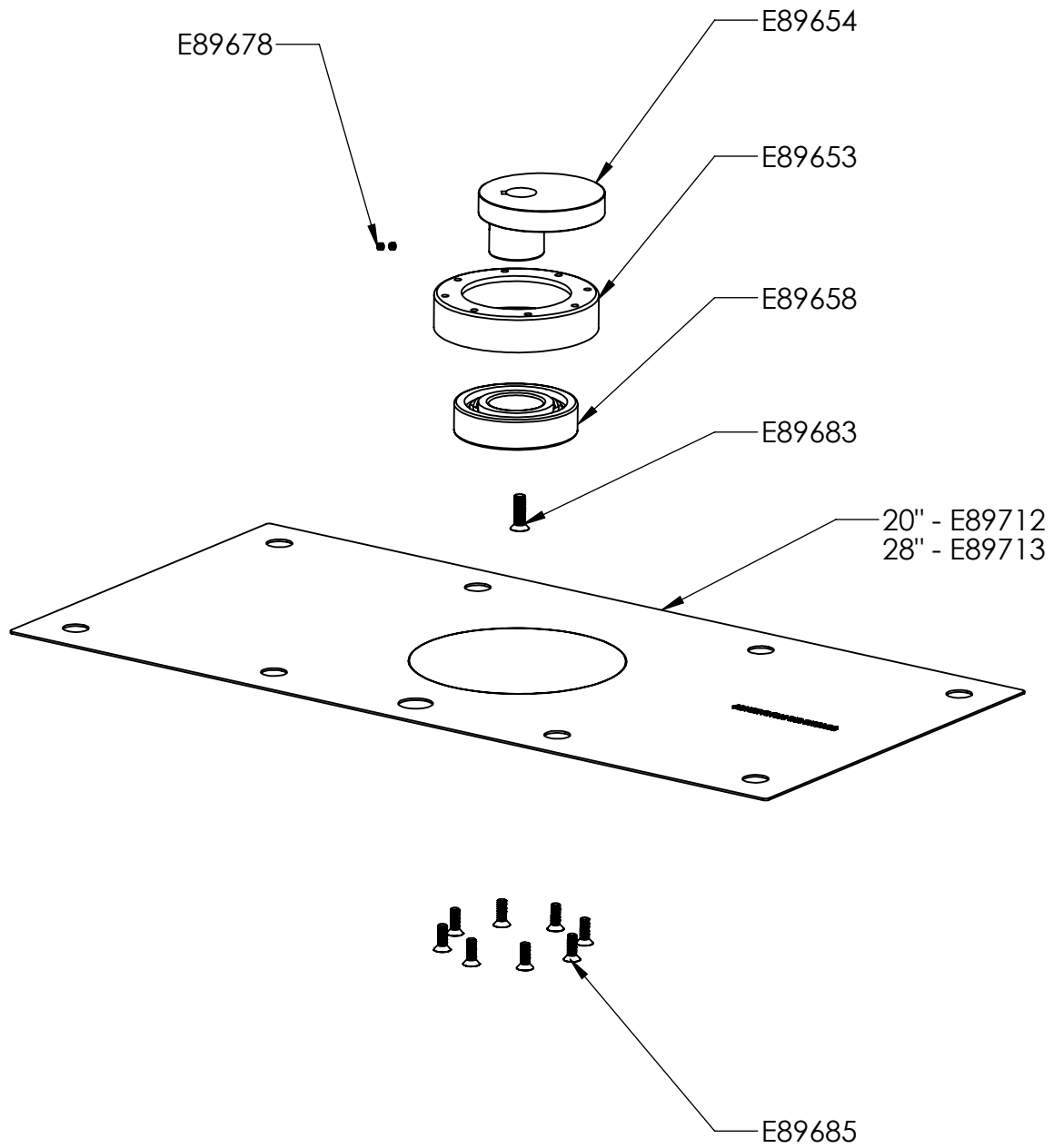



# REPLACEMENT BEARING KIT PARTS LISTING

## ITEM EP50255 - 20" BEARING KIT

Item #	Part #	Description	Qty.
1	E89653	Bearing Retainer	1
2	E89654	Eccentric	1
3	E89658	Bearing 6008 2RS	1
4	E89678	Set Screw, Socket 10-24 X 0.19 SS	2
5	E89683	Screw, Flat Head Socket 5/16-24 X 1.00 LG SS	1
6	E89685	Screw, Flat Head Philips 1/4-20 X 0.75 LG SS	8
7	E89712	20 Inch Flex Loc Pad	1

## ITEM EP50256 - 28" BEARING KIT

Item #	Part #	Description	Qty.
1	E89653	Bearing Retainer	1
2	E89654	Eccentric	1
3	E89658	Bearing 6008 2RS	1
4	E89678	Set Screw, Socket 10-24 X 0.19 SS	2
5	E89683	Screw, Flat Head Socket 5/16-24 X 1.00 LG SS	1
6	E89685	Screw, Flat Head Philips 1/4-20 X 0.75 LG SS	8
7	E89713	28 Inch Flex Loc Pad	1

# OPTIONAL DUST CONTAINMENT KIT

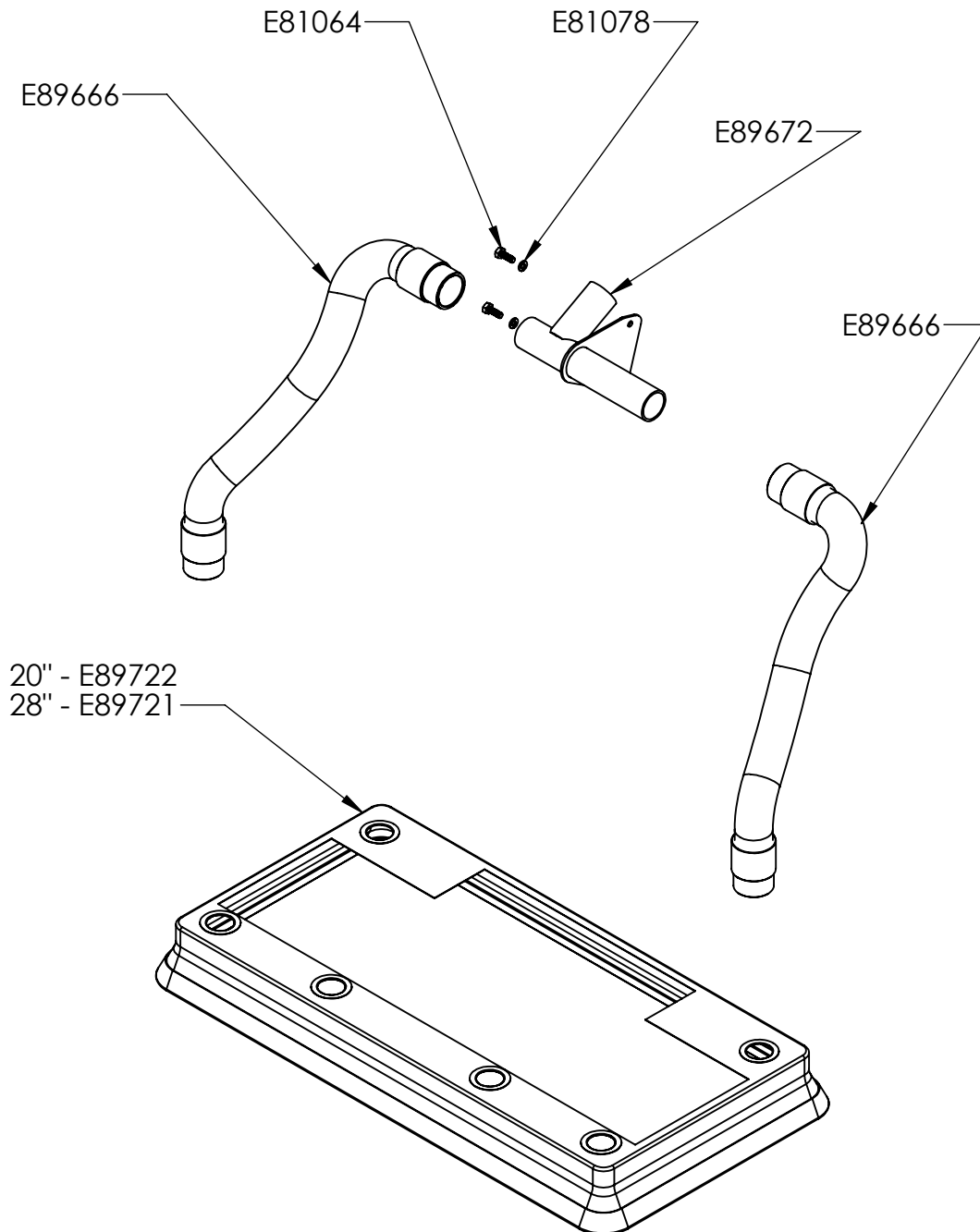

## DUST CONTAINMENT KIT PARTS LISTING

### ITEM EP50249 - 20" ORBITAL DUST CONTAINMENT KIT

<b>Part #</b>	<b>Description</b>	<b>Qty.</b>
E81064	Hex Bolt 1/4-20 x 0.75 LG Zinc	2
E81078	Lock Washer 0.250 Zinc	2
E89666	Vacuum Hose Assembly	2
E89672	Vacuum Pickup Tube	1
E89722	Dust Skirt	1

### ITEM EP50250 - 28" ORBITAL DUST CONTAINMENT KIT

<b>Part #</b>	<b>Description</b>	<b>Qty.</b>
E81064	Hex Bolt 1/4-20 x 0.75 LG Zinc	2
E81078	Lock Washer 0.250 Zinc	2
E89666	Vacuum Hose Assembly	2
E89672	Vacuum Pickup Tube	1
E89721	Dust Skirt	1

# REPLACEMENT ISOLATOR KIT

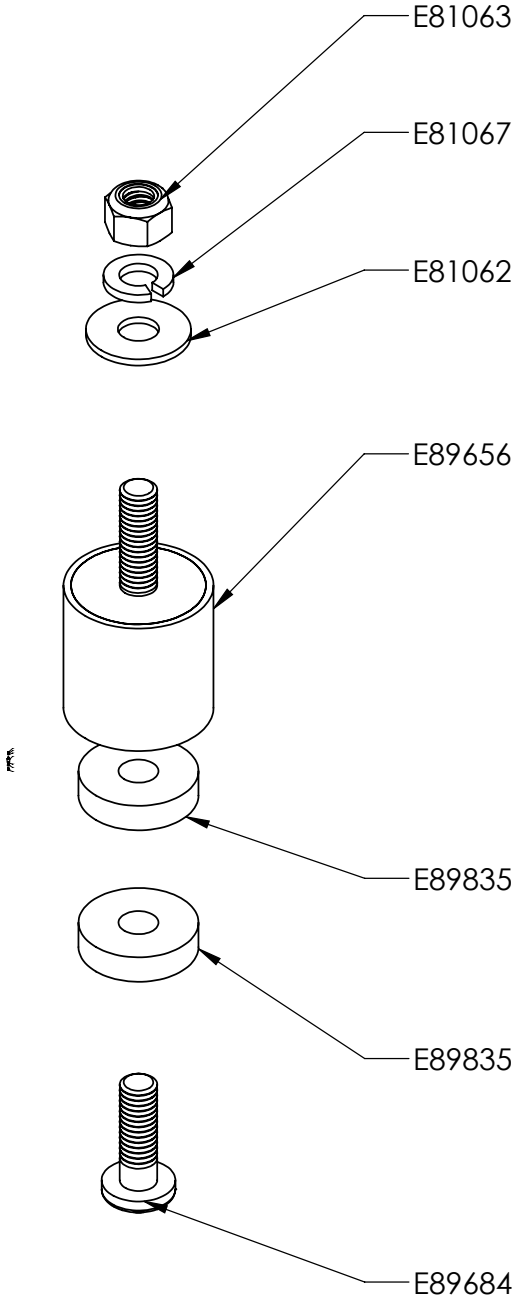

# ISOLATOR KIT PARTS LISTING

## ITEM EP50252-20" ISOLATOR KIT

Item #	Part #	Description	Qty.
1	E81062	Flat Washer 5/16 Zinc	6
2	E81063	Nyloc Hex Nut 5/16-18 Zinc	6
3	E81067	Lock Washer 5/16 Zinc	6
4	E89656	Dampener	6
5	E89684	Screw, Pan Head Philips 5/16-18 x 1.0 Lg SS	6
6	E89835	Washer, Nyloc 0.34 I.D. x 1.26 O.D. x 0.25 Thk	12

## ITEM EP50253-28" ISOLATOR KIT

Item #	Part #	Description	Qty.
1	E81062	Flat Washer 5/16 Zinc	8
2	E81063	Nyloc Hex Nut 5/16-18 Zinc	8
3	E81067	Lock Washer 5/16 Zinc	8
4	E89656	Dampener	8
5	E89684	Screw, Pan Head Philips 5/16-18 x 1.0 Lg SS	8
6	E89835	Washer, Nyloc 0.34 I.D. x 1.26 O.D. x 0.25 Thk	16





# BASIC® COATINGS U.S. WARRANTY POLICY

## 10 year coverage

Subject to the conditions stated below, Basic Coatings warrants parts and labor on rotationally molded polyethylene tanks/housings and injection molded vacuum head assemblies to be free from defects in materials and workmanship for a period of ten years to the original purchaser.

## 3 Year Coverage

Subject to the conditions stated below, Basic Coatings warrants parts and labor on all other Basic Coatings components to be free from defects in materials and workmanship for a period of three years to the original purchaser.

## 1 Year Coverage

Subject to the conditions stated below, Basic Coatings offers a limited warranty on parts and labor on the following equipment: parts and accessories to be free from defects in materials and workmanship for a period of one year to the original purchaser.

- All Tools and Accessories
- Dust Dragon Bac Pac Vac #EB85808-12

**\*Wear Items exempt from Warranty consideration include but may not be limited to: power cords, transport wheels, vacuum bags, belts, squeegee blades, pad drivers, clutch plates, handle grips, filters, screens, throttle cables, brushes and carbon brushes.**

Subject to the conditions and exceptions stated in this warranty, Basic Coatings warrants the Basic Coatings products to be free from defects in material and workmanship, under normal use and service, for the periods listed under the warranty policy to the original purchaser. At any time during the warranty period, Basic Coatings will furnish replacement parts for the Basic Coatings parts to the original purchaser. Such parts will be furnished and charged including transportation costs, to the original owner through any Basic Coatings authorized Service Distributor. If the original part is returned within the warranty policy period from date of delivery for inspection by Basic Coatings and is found to be defective the owner will be credited for the cost of replacement parts plus shipping and handling. Replacement parts that have become defective through wear or abuse are not included in this warranty.

This warranty does not apply to damage or defect caused by accident, misuse, negligence, fire, or to any Basic Coatings product which has been serviced or repaired by other than an authorized Basic Coatings Service Distributor or Basic Coatings factory personnel. This warranty is void if products are used for any purpose other than that which was intended. There are no other warranties expressed or implied. In no event shall Basic Coatings be liable for incidental or consequential damages or any damage to person or property. (Please note some states do not allow the exclusion or limitations for incidental and consequential damages).



©2016 Basic Coatings  
All Rights Reserved.  
400 Van Camp Road  
Bowling Green, Ohio 43402  
800-441-1934  
[www.basiccoatings.com](http://www.basiccoatings.com)

Item #B9175-9212 | 09/16 E